

DNA Line Filter

Dissipative Noise Attenuation Line Filter



1.0 Introduction

The DNA product line is designed to reduce the Dirty Electricity (DE) that is commonly found on AC power lines. This DE is sometimes referred-to by engineers as, "noise".

DE is energy (voltages and currents) flowing on the AC power lines that is of a higher frequency than the 50 or 60 Hz power frequency. DE is found, from, 100's of Hz to the Mhz range.

These DE voltages and currents (flowing on the AC power lines) generate electric and magnetic fields that radiate into the spaces around the power wiring. It is these fields that people have reported sensitivity-to. Therefore by using our DNA technology, the voltages and currents of the DE, that are riding on the AC power lines, are reduced. This, then, brings about a reduction the the DE fields that the DE voltages and currents produce.

DE is caused by a wide variety of devices:

- Dirty electricity coming in from the power utility company connection. This dirty electricity can be from: 1] the non-linearities in the utility company's infrastructure, e.g. transformers. This type of dirty electricity is often referred-to as "harmonics", 2] broadband dirty electricity from insulator arcing, corona/multipaction in the utility company's infrastructure, 3] poor/corroded connections within the power utility company's infrastructure, 4] dirty electricity from neighboring residential, commercial and industrial properties.
- Dirty electricity from switch mode power supplies that power various electronics which are connected to the A.C. line, including computers, off-the-grid power inverters such as solar array inverters and wind mill inverters, office machines, uninterruptible power supplies (UPS), entertainment electronics, etc.
- Dirty electricity from switch mode power supplies that are a part of lighting such a LED lights and especially compact flourescent light.
- Harmonics from traditional power supplies (not switch mode supplies) that power various electronics, noted above.
- Dirty electricity and harmonics from motor speed controls, light dimmers and solid state switches. The latter includes SCR's and Triacs.

- Harmonics from electrical motors.
- Broadband Dirty electricity from electric arc welders. This is severe, intense dirty electricity.
- Dirty electricity from induction heaters. This is severe, intense dirty electricity.
- Dirty electricity from certain Radio Frequency (RF) transmitters.

2.0 DNA Products

Many of the DNA products are simple to install and use. They plug into a standard AC outlet. These are "parallel" devices that provide a path-of-least resistance to the DE. They capture the DE and turn it into a small amount of heat. These parallel devices work to reduce DE in the frequency range, from roughly 5 khz to 500 khz. In the lower end of this range (near 5 khz) these parallel devices are not performing as well as they perform at higher frequencies – just by the nature of their design. Examples of these parallel products are: MxDNA, RxDNA-V2, PxDNA.

3.0 Alternative Power, A Source Of Dirty Electricity

3.1 Dirty Electricity Generation By Inverters

With the growing installation of alternative energy sources in recent years, there has been a significant increase in the DE in residential, commercial and industrial settings.

The most common alternative energy sources are photo-voltaic solar arrays and wind mills, aka wind turbines. These devices usually produce direct current (DC). Most, or all, of the appliances that the users have, will be alternating current (AC) appliances, at 50 or 60 Hz (cycles per second).

To accommodate this disparity between the DC available from the alternative source (solar and wind) and the AC required by the user's appliances, a device known as an Inverter is used. It is an electronic system that switches the DC on-and-off very quickly and thereby generates AC (for use by the appliances).

These Inverters are typically switch-mode-power-supplies and as a by-product they generate DE. These Inverters generate 60 Hz AC (in the US), but they do so by switching the DC on-and-off at a fundamental switch frequency, such as 16 KHz. As a result, the 60 Hz AC coming from this Inverter, will be "polluted" with the 16 KHz (in this example) switch frequency. In addition there will be numerous harmonics of the 16KHz present. For example:

$$2 \times 16 \text{ KHz} = 32 \text{ KHz}$$

$$3 \times 16 \text{ KHz} = 48 \text{ KHz}$$

$$4 \times 16 \text{ KHz} = 64 \text{ KHz}$$

etc.

These frequencies (16, 32, 48, 64 KHz), are not really intended to be a part of the 60 Hz (in this example) AC that is provided by the Inverter. They are a side effect. They represent DE.

3.2 Reducing The Dirty Electricity From Inverters

The aforementioned parallel DNA products can be used to reduce the DE from alternative energy systems, specifically the Inverter(s) that are an integral part of the system. In this approach, laboratory tests have typically shown a reduction of 10-to-1 of the DE.

In the case of alternative power, there can be Inverters that are supplying 1000's of watts of power

from the solar or wind devices. The DE from an Inverter can be considerable, and the reduction of a parallel device (such as a MxDNA, RxDNA-V2, PxDNA) may not reduce the DE to a value that is acceptable to the User (in the residential, commercial or industrial setting).

The product that we offer to accomplish a large reduction of the DE from alternative energy systems is a "line filter" device, aka "inline filter". It is the DNA Line Filter.

While the aforementioned parallel products have the considerable convenience of the user simply "plugging them in", the DNA Line Filter requires a professional electrician to install them.

The DNA-Line Filter will be connected between the Inverter and the users power wiring. The DNA Line Filter will very effectively reduce the DE from the Inverter.

As a point of comparison, the parallel devices (**MxDNA, RxDNA-V2, PxDNA**) have been tested and typically reduce the DE, **10-to-1**.

The **DNA Line Filter** testing shows typical reduction of **500-to-1** at 16 Khz and greater reductions at higher frequencies.

4.0 DNA Line Filter Specifications

Maximum Line Voltage: 250 VAC, RMS, 50/60 Hz.

Maximum Current: 30 amperes AC, RMS, 50/60 Hz.

Max wire gauge on internal terminal strip: 8 AWG

DNA Line Filter, M30, Single, Indoor: Mechanical Information



5.0 DNA Line Filter Installation

5.1 Internal Layout

Installation of the DNA Line Filter is by a professional electrician.

The DNA Line Filter is designed as a wall mount system. Mounting holes in the back wall of the unit are used to fasten the unit to a wall.

Numerous knock-outs are provided on the sides, bottom, etc. of the enclosure for connection to conduits, etc.

The image that immediately follows, shows the DNA Line Filter, M30, Single, Indoor, with the cover off, and the internal connection points within the DNA Line Filter are visible.





5.2 DNA Line Filter Single Phase (single leg) Installation

Installation of the DNA Line Filter is by a professional electrician.

Single Phase (Single Leg) Installation In An Off-grid Application. Many off-grid sites (homes, commercial, etc.) operate with only 1 phase. There is an energy source, such as wind turbine or solar array, that supplies DC (direct current) power to a single DC-to-AC-Inverter. The Inverter then provides 50 Hz or 60 Hz AC (alternating current) to the user's appliances. This AC power is typically quite polluted by DE. A single DNA-Line-Filter (as the following drawing shows) is inserted into the AC power line between the Inverter output and the AC distribution panel (aka circuit breaker box / fuse panel, etc.)

Single Phase (Single Leg) Installation In An Augmented Application. When there is an existing site (home, commercial, etc.) that is powered from the grid with a traditional 2-Phase (2 Leg) connection, there is a common approach where solar/wind generation will be added to the site as an augmentation. The AC power from the Inverter(s) of the solar/wind infrastructure can supply 50/60 Hz AC power either as single phase or as 2-Phase (2 Leg). In the case where the solar/wind infrastructure is supplying only 1 Phase, from a single Inverter, then the DNA-Line-Filter can be inserted into the connection from the Inverter, and the output of the DNA-Line-Filter can be connected to only one of the existing Phases (Legs) in the distribution panel.

The DNA Line Filter must be protected from excessive incoming current. Many Inverters have internal current limiting that can accomplish this protection.

In the event that the Inverter that is feeding the DNA Line Filter does not have internal current limiting or does not have sufficient current limiting, then a dedicated circuit breaker must be provided, at installation, between the Inverter output and the DNA Line Filter input. See the following 2 drawings.

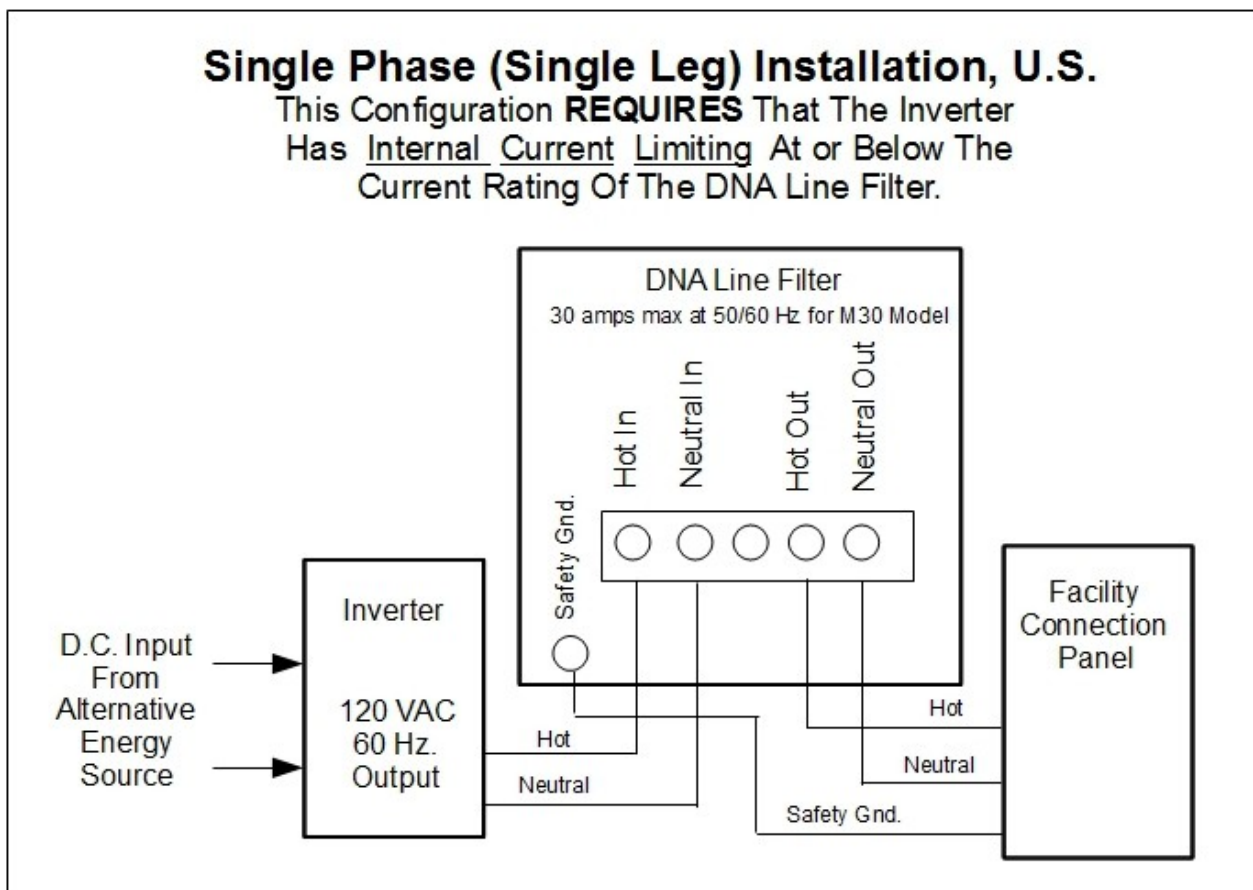

Single Phase (Single Leg) Installation, U.S.

This Configuration Utilizes A Dedicated
Circuit Breaker, At or Below The
Current Rating Of The DNA Line Filter.

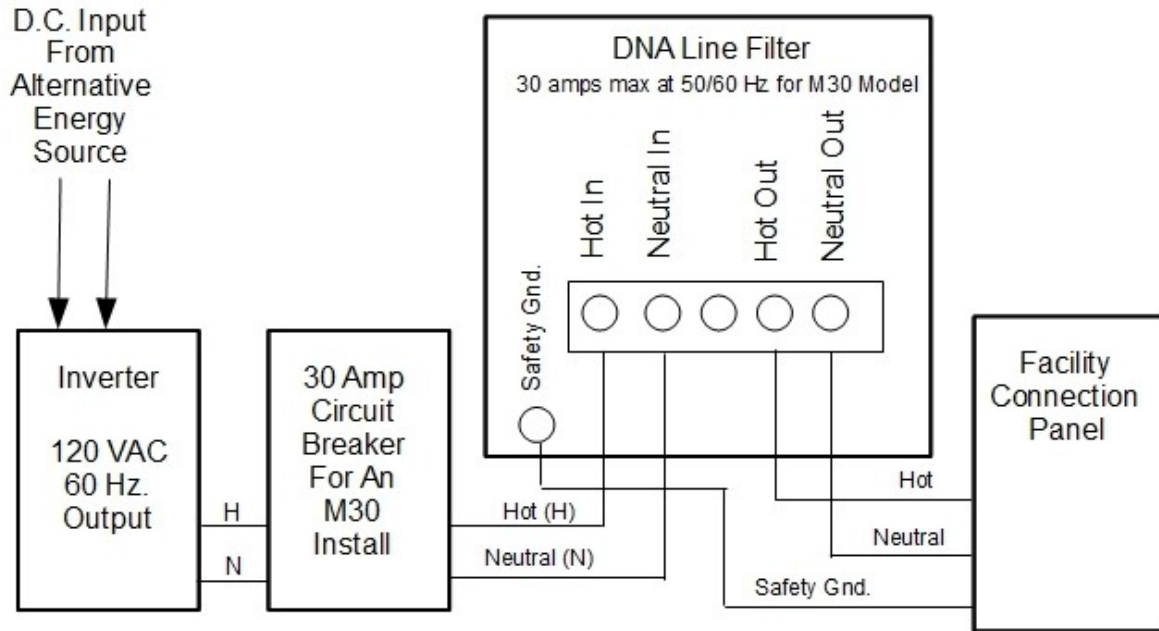

5.3 DNA Line Filter Two Phase (two leg) Installation

Installation of the DNA Line Filter is by a professional electrician.

The 2 drawings that immediately follows, shows the interconnections of the DNA Line Filter in a generic way.

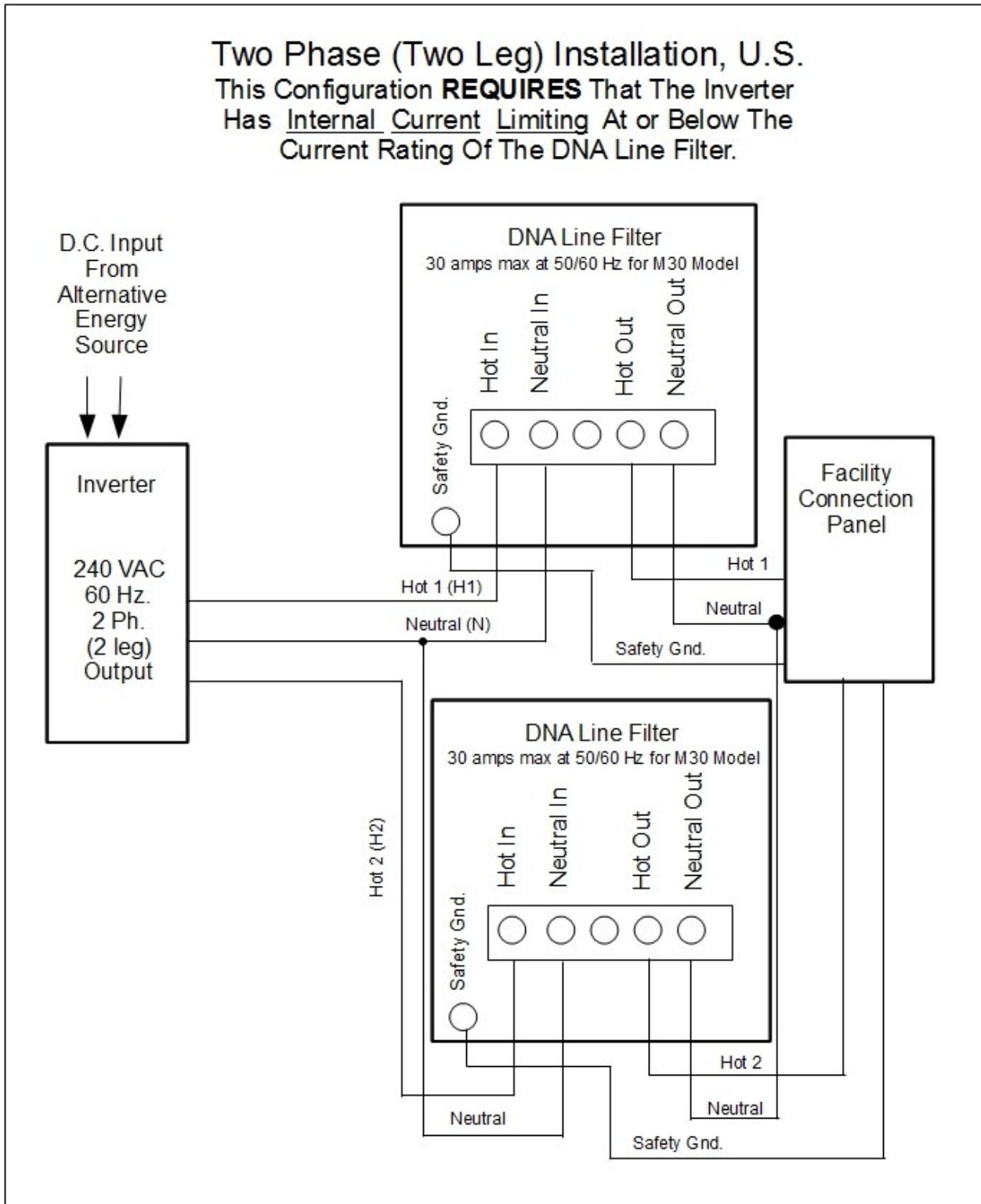

Two Phase (Two Leg) Installation, U.S.

This Configuration Utilizes A Dedicated
Circuit Breaker, At or Below The
Current Rating Of The DNA Line Filter.

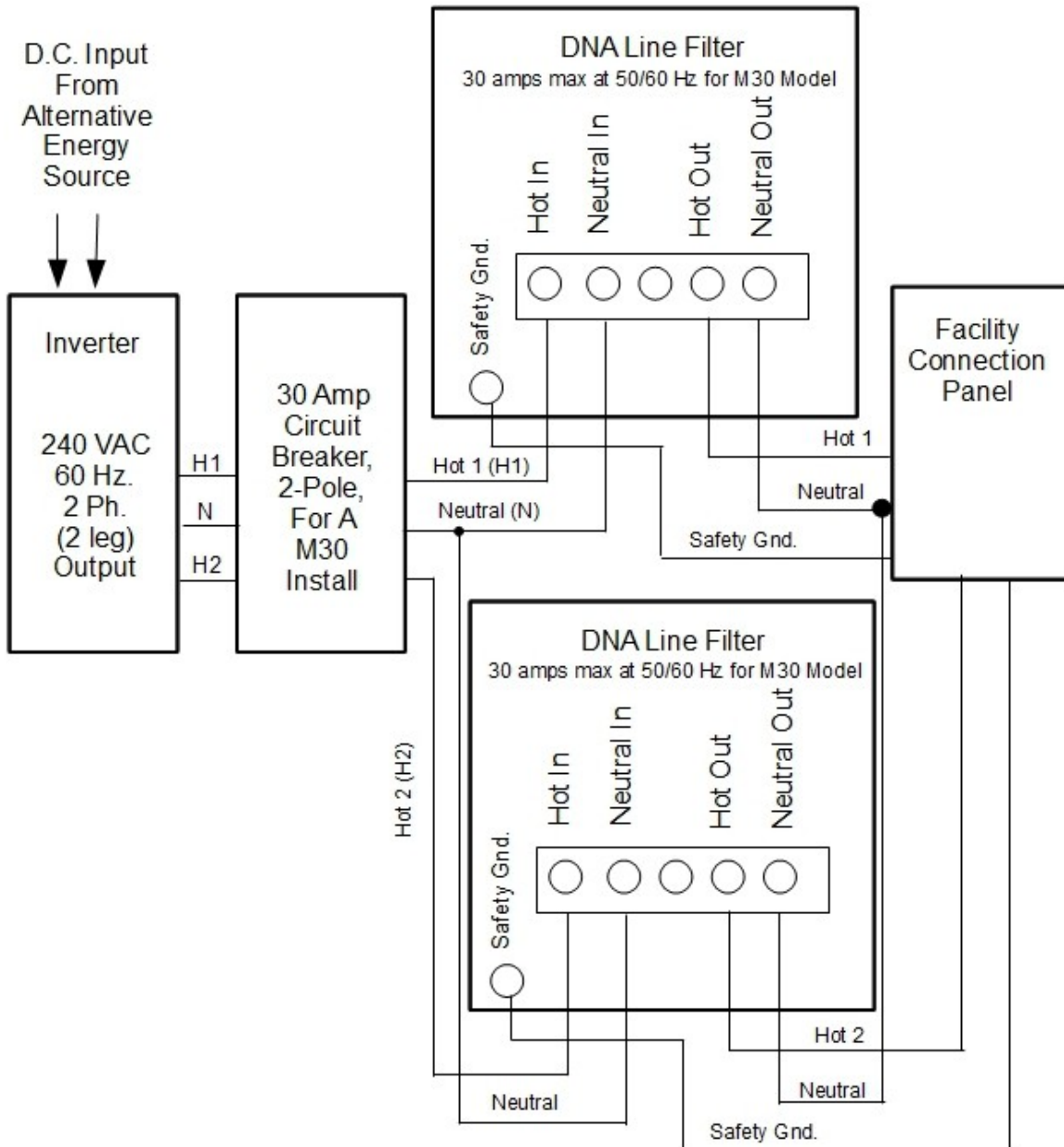

Two Phase (Two Leg) **DUAL** Installation, U.S.

This Configuration **REQUIRES** That The Inverter Has Internal Current Limiting At or Below The Current Rating Of The DNA Line Filter.

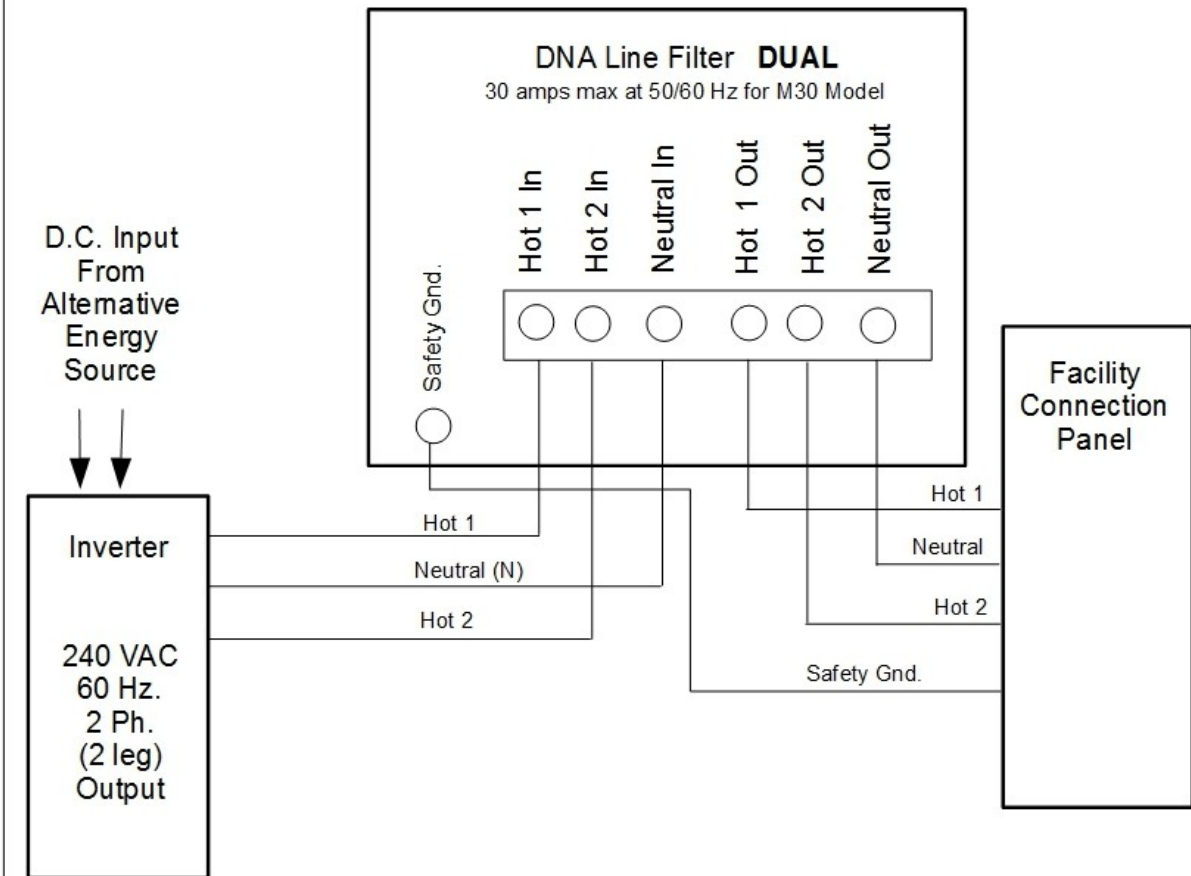

Two Phase (Two Leg) **DUAL** Installation, U.S.

This Configuration **REQUIRES** That The Inverter Power Is Fed Through Circuit Breaker At or Below The Current Rating Of The DNA Line Filter.

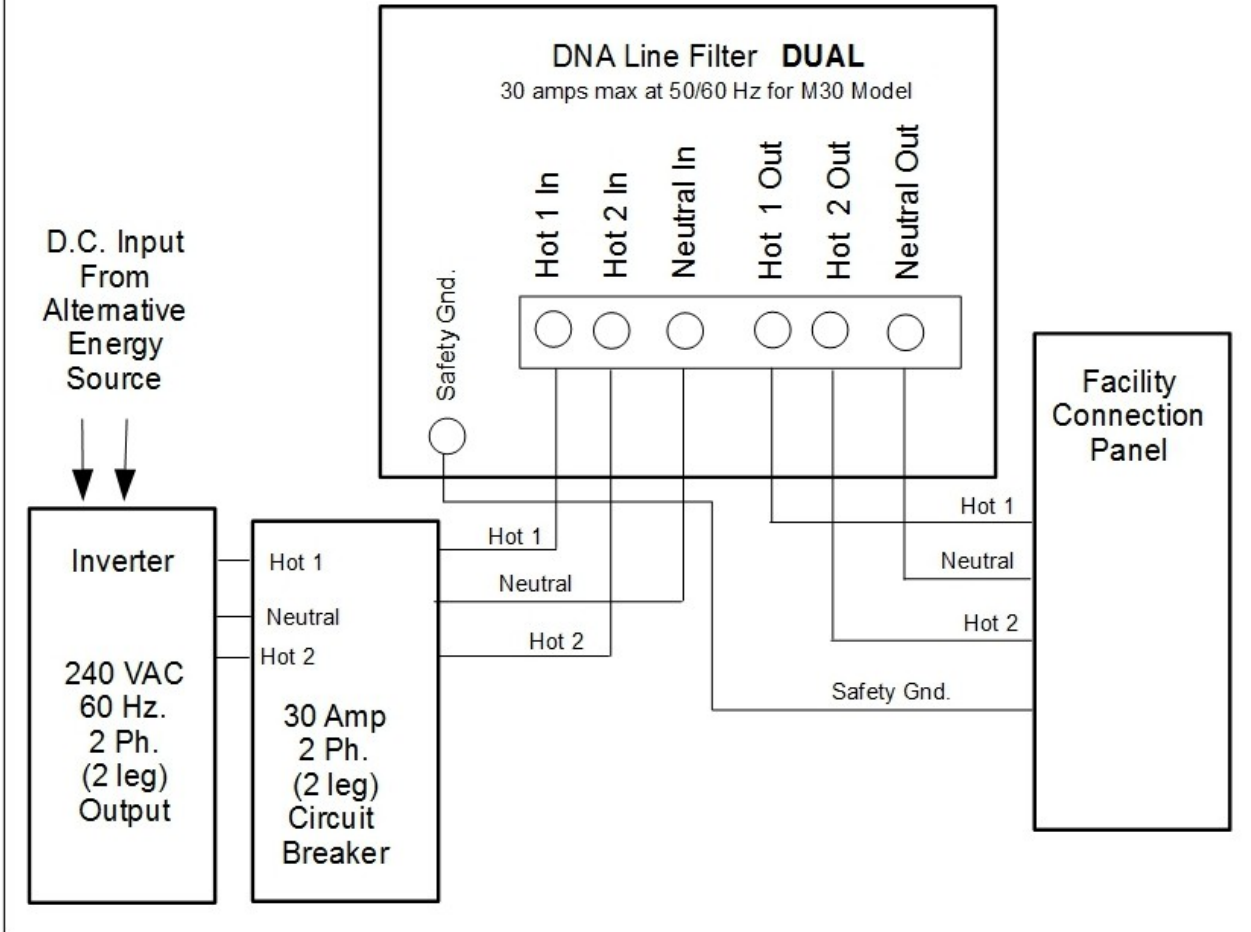

6.0 DNA Line Filter Operation Notes

6.1 Overall Operation

The DNA Line Filter has a massive inductor at the core of its design. As with all inductors and transformers there is some humming and buzzing associated with this device.

Humming and buzzing from an inductor is caused by stray magnetic fields, emanating from the inductor, causing the enclosure and accessories to vibrate. In addition, Magnetostriction is a second source of vibration (and thereby humming and buzzing), where the iron core of the inductor changes shape minutely when exposed to magnetic fields.

The humming and buzzing will depend upon the load current placed on this device. If the humming/buzzing seems loud, then it is likely that there are loads, within the facility (residential, commercial, industrial) that are drawing current in a pulsed fashion.

An example is a portable electric heater that has a pulse-width-modulation controller to set the amount of heat being produced.

While most heaters have a simple on-off thermostat to regulate the heat, a few heaters have a pulse-width-modulation scheme and will be turning the power off-on-off-on at the power line frequency (50/60 Hz). These pulses of current will often be considerable (10 to 12 amperes) and this will result in loud humming/buzzing in the inductor.

While this humming/buzzing will not affect the filtering performance of the DNA Line Filter, the sound may be objectionable.

In the cases where humming or buzzing does occur, and if the user finds humming or buzzing objectional, the DNA Line Filter can be mounted outdoors, in a weatherproof enclosure, on a pedestal, i.e. not mounted on the building that is occupied. The weatherproof enclosure and pedestal can be provided by the installing electrical contractor.

It is important to note that the idea of installing the DNA Line filter is to reduce DE in the facility. A heater that pulses on-off-on-off at the power line frequency, will be generating DE within the facility and it will be very powerful DE, that likely will extend up to the hundreds of kilohertz in range. Since this DE is down-stream of the DNA Line Filter, there will be no attenuation of this internally-generated DE, by the DNA Line Filter. Users who want low DE in their facility, would be well advised to not use such potent "DE generators" (the pulsed heater).

6.2 Internal Circuit Breaker and Panel Lamp

The DNA Line Filter has an internal circuit breaker that interrupts the current flow to the DNA dissipative electronics, if the Dirty Electricity current is too high, into those electronics. It is unlikely that this could ever happen because of the high impedance that the DNA Line filter inductor presents to the DE. Nevertheless it is a prudent part of a safe design.

The DNA Line Filter front panel lamp is connected on the load side of the aforementioned circuit breaker. If the circuit breaker is on, then the unit is functioning normally and the panel lamp will be on. If the circuit breaker has cycled off, then the panel lamp will be off.

In the case where the lamp is seen to be off, then reset the breaker and see if the panel lamp stays on. If for any reason the circuit breaker continues to cycle off, please contact the factory for troubleshooting information.

Visit us on the web: <http://mxdna.com>

7.0 Theory Of Filtering and Isolation Mode Connections

On the following pages, there are diagrams and photos that are specifically related to the Isolation Mode configurations.

Hot In (aka In Hot), to the filter is the dirty electricity source, e.g.: solar inverter, variable speed pump, variable speed HVAC, any device that makes dirty electricity, a sub panel with devices, the utility grid for a whole house filter.

Hot Out (aka Out Hot) of the filter is the protected side and gets connected to the main power panel or to a critical loads sub panel.

DNA Line Filter Connected In Isolation Mode Single Phase Mode R7

Noisy Load
Example: Pool pump with noisy switching converter, solar inverter, variable speed pump, variable speed HVAC, any device that makes dirty electricity.

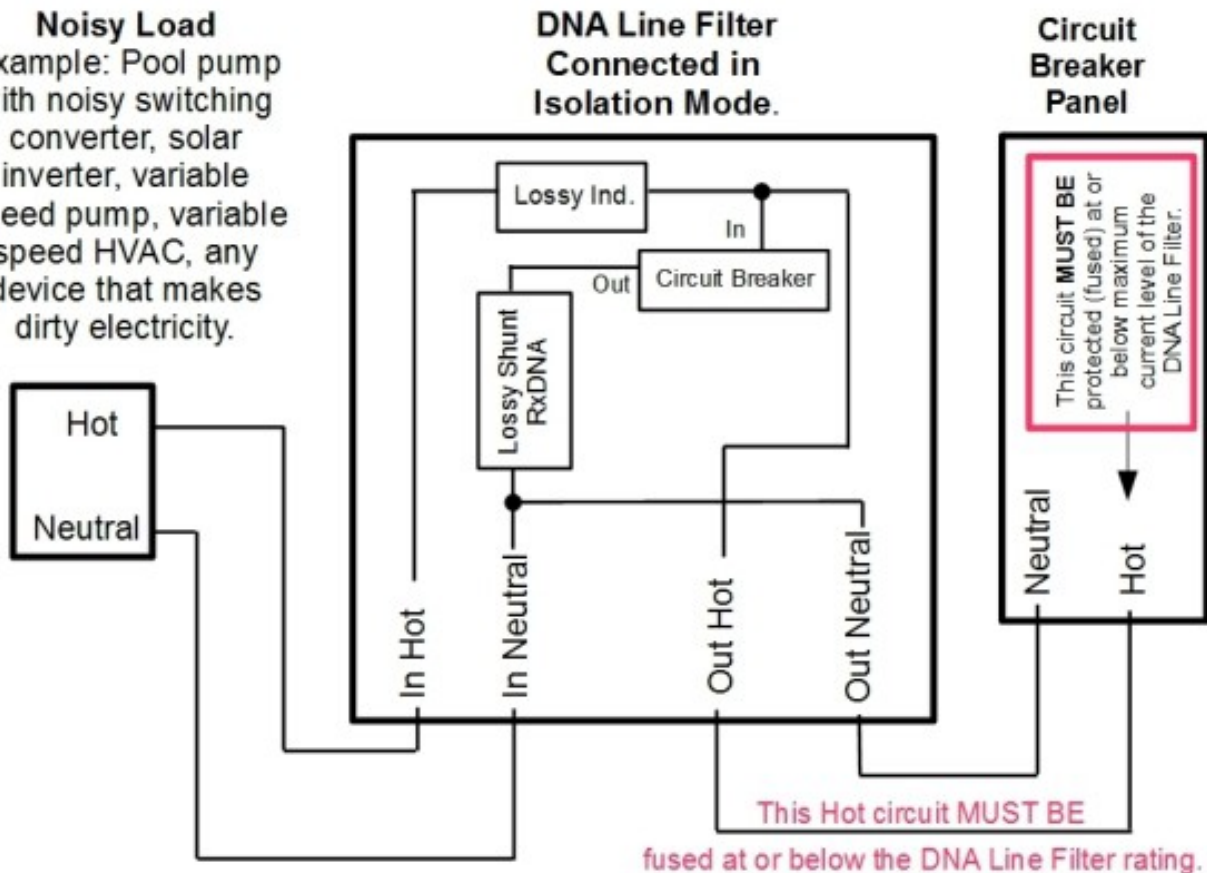

Very, Very Important

In this drawing, the designation "In" refers to the source of Dirty Electricity (DE). It may or may not be the source of 50/60 Hz power.

Examples:

- In the case of an inverter for a solar or wind generation source, the Solar or Wind Inverter output connects to the "In" terminal of the DNA filter.
- In the case of filtering all of the power from a power utility provider, the 50/60 Hz power source from the utility provider, connects to the "In" terminal of the DNA filter (properly fused!).
- In the case of a DE-generating load, such as a pool-pump, switching HVAC, etc, the 50/60 Hz power connects to the "Out" terminals, and the DE-generating load connects to the "In" terminal of the DNA filter.

Always connect the "source" of DE to the "In" terminals.

DNA Line Filter Connected In Isolation Mode Single Phase Mode With Subpanel R4

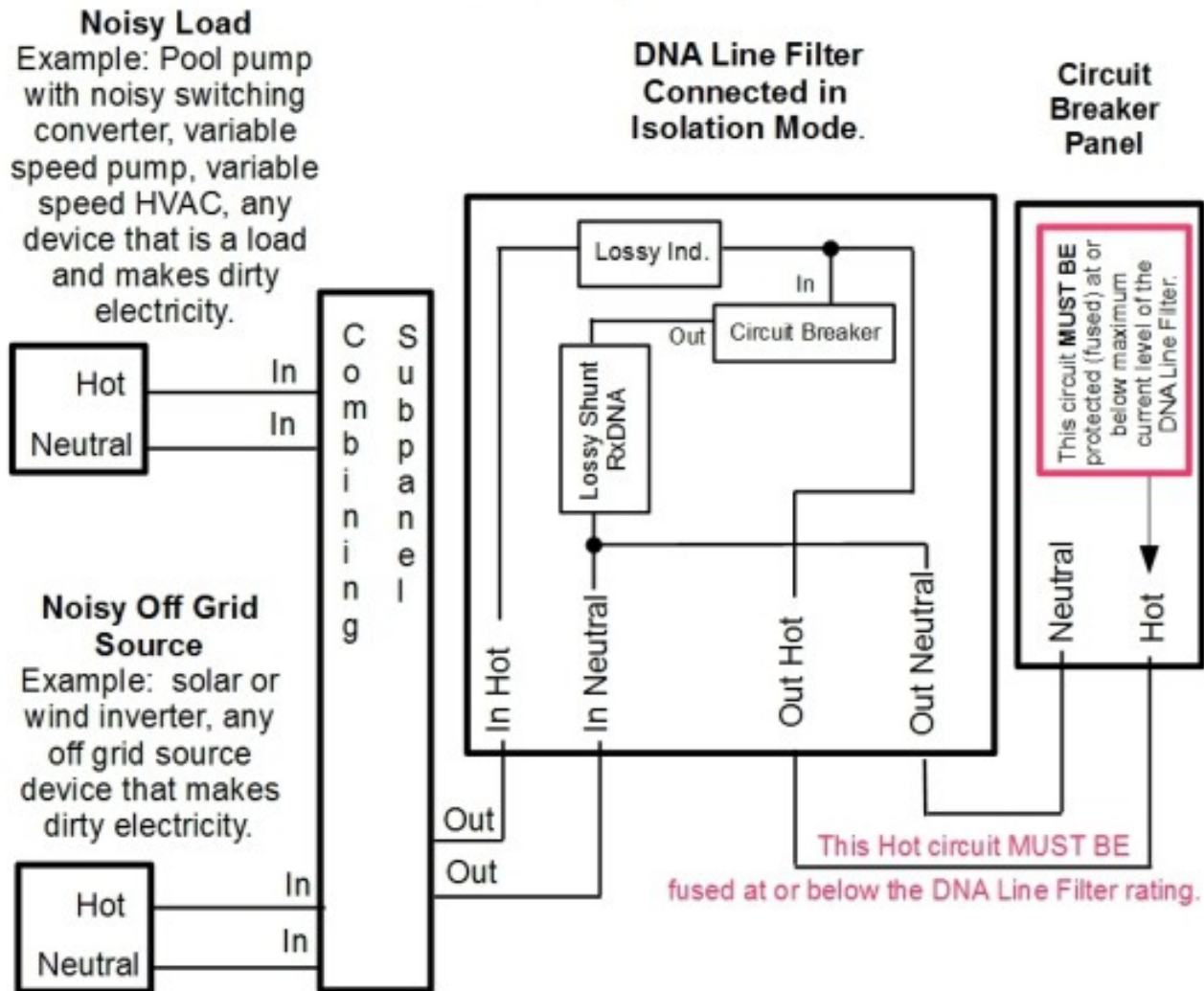

Very, Very Important

In this drawing, the designation "In" refers to the source of Dirty Electricity (DE). It may or may not be the source of 50/60 Hz power.

Examples:

- In the case of an inverter for a solar or wind generation source, the Solar or Wind Inverter output connects to the "In" terminal of the DNA filter.
- In the case of filtering all of the power from a power utility provider, the 50/60 Hz power source from the utility provider, connects to the "In" terminal of the DNA filter (**properly fused !**).
- In the case of a DE-generating load, such as a pool-pump, switching HVAC, etc, the 50/60 Hz power connects to the "Out" terminals, and the DE-generating load connects to the "In" terminal of the DNA filter.

Always connect the "source" of DE to the "In" terminals.

DNA Line Filter M30 Dual Indoor – Inside Wiring

